

LOS ANGELES FIRE DEPARTMENT



KRISTIN M. CROWLEY
FIRE CHIEF

January 7, 2025

BOARD OF FIRE COMMISSIONERS
FILE NO. 25-006

TO: Board of Fire Commissioners

FROM:  Kristin M. Crowley, Fire Chief

SUBJECT: IN-KIND DONATION OF WASHER AND DRYER TO FIRE STATION 11

FINAL ACTION:	<input type="checkbox"/> Approved	<input type="checkbox"/> Approved w/Corrections	<input type="checkbox"/> Withdrawn
	<input type="checkbox"/> Denied	<input type="checkbox"/> Received & Filed	<input type="checkbox"/> Other

SUMMARY

The Los Angeles City Fire Department Foundation (LAFDF) has graciously donated a new, high-efficiency, Speed Queen top load washer and front load dryer to Fire Station 11. Fire Station 11 is one of the busiest fire stations in the City with approximately 18 members on duty on any given shift and over seven apparatus in service. The purpose of this equipment is to replace existing units that are starting to fail and in need of maintenance due to constant use. The washer and dryer are used for laundry needs for clothing, towels, and other items requiring sanitization. The value of the donation is \$3,545.61.

RECOMMENDATIONS

That the Board:

Receive and approve this report for the In-Kind Donation by the Los Angeles Fire Department Foundation for the items listed above, valued at \$3,545.61 to the Los Angeles Fire Department.

FISCAL IMPACT

There is no fiscal impact on the Department’s budget from the acceptance of this donation. Donations provide the necessary items to meet the needs of the respective fire stations or administration sections. Replacement or repair of items meeting City specifications and Fire Department business needs may be borne by General Fund, subject to budgetary constraints.

CONCLUSION

The Los Angeles Fire Department benefits tremendously from gracious donations and support. The LAFD acknowledges the LAFDF for its generosity.

Board report was prepared by Senior Management Analyst I, Betty Cornejo, Chief of Staff Office.

Attachment



**WASH MULTIFAMILY LAUNDRY SYSTEMS
EQUIPMENT SALES AGREEMENT**

AGREEMENT NO.

CUSTOMER ULN

BILL TO PURCHASER
 CUSTOMER NAME (LEGAL):
 STREET ADDRESS
 CITY, STATE, ZIP CODE
 CONTACT
 CONTACT #

Los Angeles Fire Department Foundation
 1700 Stadium Way #100
 Los Angeles CA 90012
 Robin Blau Email: Robin@supportlafd.org
 310-487-2400

SHIP TO ADDRESS
 BUILDING NAME
 STREET ADDRESS
 CITY, STATE, ZIP CODE
 CONTACT
 CONTACT #

LAFD Fire Station 11
 1819 W 7th St
 Los Angeles CA 90703
 Jein Wen Lin
 213-485-6211

SERVICE BRANCH 01 - LA/OC	SHIP VIA	F.O.B.	PAYMENT TERMS PAY IN FULL
P.O. NUMBER	DATE August 12, 2024	SALESPERSON Lori Thomas	PAYMENT METHOD Credit Card

Machines Only

MODEL NUMBER	DESCRIPTION	TYPE	QUANTITY	UNIT PRICE	EXTENDED PRICE
SWNNY2SP116TW01	Speed Queen Top Load Single Washer Coinless	Washer	1	\$1,699.00	\$1,699.00
SDGNRYGS116TW01	Speed Queen Gas Single Dryer Coinless	Dryer	1	\$1,399.00	\$1,399.00

Card Equipment Only

Card Equipment Only	DESCRIPTION	TYPE	QUANTITY	UNIT PRICE	EXTENDED PRICE

Special Instructions Install: Eq will run free with zero dollar vend. No equipment to remove.	EQUIP. TOTAL	\$3,098.00
	FREIGHT	\$40.00
<input type="checkbox"/> Full Payment Received:	D & I	\$100.00
Balance: <u>\$3,545.61</u>	SUBTOTAL	\$3,238.00
<input type="checkbox"/> Tax Exempt Number:	TAXES 9.50%	\$307.61
	TOTAL	\$3,545.61

Payment Contact: Robin Blau 310-487-2400
 Order Number: 0 Email: See above
 Equipment Tax Freight Tax Delivery Tax

All Equipment remains the property of WASH Multifamily Laundry Systems. ("WASH") until payment in full is received. Any damaged Equipment must be reported to carrier and Vendor by Purchaser immediately upon receipt of damaged Equipment by Purchaser.
 NO returns accepted after Equipment use. Returns ONLY accepted for Equipment that is damaged at delivery. Cancellations, if accepted by WASH prior to delivery, is subject to a 25% restocking fee.
 All overdue invoices are subject to a finance charge of 2% per month (26.82% per annum) or the highest rate permitted by law. All purchases are subject to the conditions of sale on page 2 of this document.
THIS AGREEMENT COMMENCES ON RECEIPT OF FULL PAYMENT FOR THE EQUIPMENT BY WASH.

Customer:
 Los Angeles Fire Department Foundation
 Per: Robin Blau
 Robin Blau
 Print Name
 8/13/24
 YY/MM/DD
 I have authority to bind the Purchaser.

Vendor:
 WASH MULTIFAMILY LAUNDRY SYSTEMS
 Per: _____

 Print Name

 YY/MM/DD
 I have authority to bind the Vendor.

TERMS AND CONDITIONS OF EQUIPMENT SALES AGREEMENT

1. **Sale** – WASH Multifamily Laundry Systems, (the "Vendor" or "WASH") agrees to sell and the purchaser named on page 1 of this document (the "Purchaser") agrees to buy the equipment ("Equipment") described therein or in an attachment hereto subject to the terms and conditions provided herein and thereon. Any purchase order or other document issued to the Vendor by the Purchaser related to the Equipment or this agreement ("Agreement") is issued for authorization purposes only and none of the terms or conditions thereof shall modify or supersede the terms or conditions of this Agreement, which shall control for all purposes.
2. **Payment** – The Purchaser agrees to pay the Vendor the full price plus applicable taxes in advance of shipment. Overdue payments are subject to interest of 2% per month (26.82% per year) or the highest rate permitted by law. All Sales Final. No returns accepted for any Equipment after use. All returns require an authorization number, and will only be accepted for Equipment arriving damaged at delivery. Cancellations prior to delivery of Equipment are subject to a 25% restocking charge at Vendor's discretion. Check payments, including certified checks, require five (5) business days to clear. Payment by credit card may require government photo identification of the credit card owner prior to acceptance. In the event of default in payment by the Purchaser, the Vendor shall have the rights and remedies of a secured creditor as provided by applicable law including the right to enter the premises where the Equipment is located and repossess same without liability.
3. **Title** – Title to and ownership of the Equipment shall at all times remain with the Vendor until the purchase price has been paid in full. Until the purchase price has been paid in full to secure its obligations to the Vendor hereunder, the Purchaser hereby grants a contingency and fixed security interest in all of its rights, title and interest in and to the Equipment and all proceeds in any form derived directly or indirectly from any dealing with the collateral or any part thereof, and all proceeds thereof, and to the extent the Purchaser can grant a security interest in the Equipment, the Purchaser hereby does so. In both cases to the Vendor until payment in full has been received by the Vendor. To the extent permissible by law, the Purchaser waives all rights of notice or receipt of any financing statement, financing change statement or other documentation of any security interest notice registered against the Purchaser which may be filed at any time by the Vendor. The Equipment shall remain personal property even though installed or attached to real property. If the Equipment is not being installed or used at the place of delivery, the Purchaser covenants and agrees to provide the address of the final location of the Equipment on page 1 of this Agreement.
4. **Risk of Loss** – The risk of loss or damage to the Equipment transfers to the Purchaser at the time of physical delivery to the Purchaser. The Purchaser covenants and agrees that any loss, destruction or damage to the Equipment shall not release the Purchaser from the obligation to make payment in full of the purchase price and to be bound by the terms of this Agreement.
5. **Delivery** – Vendor will use commercially reasonable efforts to perform hereunder. However, Vendor is not liable for delays in delivery of Equipment caused by government orders or regulations, war, unavailability of parts or equipment from the manufacturer, fires, strikes, work stoppages, transportation delays, material scarcity, acts of God or any other cause beyond Vendor's control. The Purchaser is responsible for:
 - a) payment in full of all amounts owing to Vendor pursuant to this Agreement;
 - b) confirmation of acceptance of the Vendor's delivery date in writing;
 - c) clearing obstructions from the delivery area;
 - d) being present at time specified by Vendor for delivery. Failure to accept delivery at the arranged time will result in a re-delivery charge of \$200.00 per item;
 - e) inspecting and accepting the Equipment as conforming to the terms of the Equipment as described in this Agreement, including (i) confirmation that the Equipment has been delivered in good condition, and (ii) signing off on the delivery acknowledgement document or immediately declaring Equipment damage to carrier. Failure by Purchaser to notify the carrier and the Vendor of damage to the Equipment within one (1) day of delivery shall be deemed as acceptance of the Equipment by Purchaser for all purposes; and
 - f) installation of the Equipment according to the Equipment manufacturer's specifications where installation of the Equipment has not been purchased from the Vendor. Installation of the Equipment by the Purchaser, its employees, agents or subcontractors which does not comply with the Equipment manufacturer's installation specifications will void the Equipment warranty by Vendor and the Equipment manufacturer, and neither the Vendor nor the Equipment manufacturer will be liable for injury or damage to property or personal injury (including death) resulting from such non-compliant Equipment installation.
6. **Limited Equipment Warranties** – All new Equipment sold to Purchaser by Vendor shall be covered by the terms and subject to the limitations of (i) Vendor's 90-day limited warranty on parts and labor (the "Vendor's Limited Warranty"), and (ii) the applicable Equipment manufacturer's limited warranty ("Manufacturer's Limited Warranty"). Please consult your owner's manual for warranty information, terms and limitations. **THE VENDOR'S LIMITED WARRANTY AND THE MANUFACTURER'S LIMITED WARRANTY ARE IN LIEU OF ALL OTHER WARRANTIES, EXPRESS OR IMPLIED, AND THE IMPLIED WARRANTIES OF MERCHANTABILITY, FITNESS FOR A PARTICULAR PURPOSE AND NON-INFRINGEMENT ARE HEREBY EXPRESSLY EXCLUDED. THE VENDOR'S LIMITED WARRANTY AND THE MANUFACTURER'S LIMITED WARRANTY SHALL NOT APPLY TO EQUIPMENT WHICH HAS BEEN DAMAGED, ALTERED, MISUSED OR IS OTHERWISE EXCLUDED BY THE TERMS OF THE VENDOR'S LIMITED WARRANTY OR THE MANUFACTURER'S LIMITED WARRANTY.**
7. **Liability** – Except to the extent of the negligent acts or omissions by the Vendor, its employees, agents or contractors, to the fullest extent allowed under applicable law, the Vendor shall not be liable and the Purchaser (including anyone claiming by or through Purchaser) shall (i) hold Vendor harmless for and from any damages, actions, claims, costs, losses, or expenses (including attorneys' fees) resulting or arising from or claimed to have resulted or arisen from the sale, use, delivery, installation, hookup, operation or performance of the Equipment or this Agreement, regardless of the form of damages, action or suit and (ii) indemnify and defend the Vendor for and from any damages, actions, claims, costs, losses, or expenses (including attorneys' fees with legal counsel of Vendor's choice) suffered by Vendor resulting or arising from or claimed to have resulted or arisen from the sale, use, delivery, installation, hookup, operation or performance of the Equipments or this Agreement, regardless of the form of damages, action or suit. In no event shall the Vendor be liable for any incidental, special, indirect, consequential damages, loss of profits, loss of use, or failure of cost savings resulting from or in any way relating to the sale, use, delivery, installation, hookup, operation or performance of the Equipment.
8. **Default** – The Purchaser shall be in default under this agreement upon the occurrence of any of the following events ("Events of Default"):
 - a) the Purchaser defaults in the payments or performance of any of the Purchaser's obligations pursuant to this Agreement ("Obligations");
 - b) the death, insolvency, bankruptcy or business failure of manager of any part of the property of the Purchaser, or the commencement by or against the Purchaser of any proceeding under any bankruptcy, arrangement, reorganization, dissolution, liquidation, insolvency or similar law for the relief of or otherwise affecting creditors of the Purchaser, or by or against any guarantor or surety for the Purchaser, or upon the issue of any writ of execution, warrant, attachment, sequestration, levy, third party demand or garnishment or similar process against the Purchaser or any part of the Equipment;
 - c) the institution by or against the Purchaser of any formal or informal proceeding for the dissolution or liquidation of, settlement of claims against or winding up of affairs of the Purchaser, the Purchaser makes or proposes to make any sale of its assets in bulk, or WASH in good faith believes the prospect of payment or performance of the Obligations hereunder is impaired. Upon the occurrence of an Event of Default all of the Obligations shall become immediately due and payable without notice to the Purchaser, and WASH may, at its option, proceed to enforce payment of same and to exercise any or all of the rights and remedies contained herein or otherwise afforded by law, in equity or otherwise. WASH shall have the right to enforce one or more remedies successively or concurrently in accordance with applicable law and WASH (or any representative or agent of WASH) may upon such Event of Default:
 - d) immediately and without notice enter the Purchaser's premises, including without limitation any and all premises that the Purchaser has any right to occupy, enter or possess or for which the Purchaser has any right of beneficial or legal ownership, and repossess, disable or remove the Equipment without liability, and the Purchaser hereby grants to WASH a license to occupy any premises of the Purchaser for the purpose of storage of the Equipment;
 - e) retain and administer the Equipment in WASH's sole and unfeathered discretion, which the Purchaser hereby acknowledges is commercially reasonable;
 - f) dispose of any Equipment by public auction, private tender or private contract with or without notice, advertising or any other formality, all of which are hereby waived by the Purchaser. WASH may, at its discretion establish the terms of such disposition, including, without limitation, terms and conditions as to credit, upset, reserve bid or price. WASH may also lease the Equipment on such terms, as it deems appropriate. The payments for the Equipment, whether on a disposition or lease, may be deferred. All payments made pursuant to such dispositions shall be credited against the Obligations only as they are actually received. WASH may buy in, rescind or vary any contract for the disposition of any Equipment and may dispose of any Equipment again without being answerable for any loss occasioned thereby. Any such disposition may take place whether or not WASH has taken possession of the Equipment; and
 - g) pay any lien, charge or encumbrance that may exist or be threatened against the Equipment. In any such case the amounts so paid together with costs, charges and expenses incurred in connection therewith shall be added to the Obligations secured by this Agreement.
9. **Entire Agreement** – The Purchaser agrees that it has read this Agreement, understands it and agrees to be bound by its terms and further agrees that it is the complete and entire agreement between the parties which supersedes and merges all other prior proposals, quotations, understandings, and agreements, oral or written between the parties, relating to the subject matter hereof. For greater clarity, any terms and conditions in any other document which are inconsistent with, attempt to add to, or attempt to amend the terms and conditions of this Agreement shall be deemed null and void and of no legal effect. This Agreement may not be modified or altered except by written instrument duly executed by both parties.
10. **Governing Law** – This Agreement shall be governed and construed in accordance with the laws of the state in which the Equipment was delivered.
11. **Enforceability** – Any provision of this Agreement prohibited by law or otherwise ineffective shall be ineffective only to the extent of such prohibition or ineffectiveness and shall be severable without invalidating or otherwise affecting the remaining provisions hereof.
12. The Purchaser agrees not to change its places of business or change its name or any name under which it carries on business prior to Vendor's receipt of payment in full for the Equipment, without giving to WASH twenty (20) days prior written notice via certified return receipt requested mail of the change.
13. The Purchaser will and shall be deemed to hold all proceeds of the Equipment in trust, separate and apart from other money, instruments or property, for the benefit of WASH until all amounts owing by Purchaser to WASH have been paid in full.
14. WASH shall not have any liability by reason of any entry into or taking possession of any of the Equipment as allowed by the terms of this Agreement.
15. The Purchaser will reimburse WASH on demand for all costs and expenses (including the full amount of legal fees and expenses paid by WASH) incurred by WASH in connection with enforcement of this Agreement, the realization, disposition of, retention, protection, insuring or collection of any Equipment, the protection or enforcement of the rights, remedies and powers of WASH. All amounts for which the Purchaser is required hereunder to reimburse WASH shall, from the date of disbursement until the date WASH receives reimbursement, bear interest at the highest rate per annum charged by WASH on any of the Obligations and allowed under applicable law.
16. The rights, remedies and powers conferred by this agreement are in addition to, and not in substitution for, any other rights, remedies or powers WASH may have under this agreement, at law, in equity or by under any status.
17. The Purchaser shall at all times, do, execute, acknowledge and deliver or cause to be done, executed, acknowledged or delivered all such further acts, deeds, transfers, assignments, security agreements and assurances as WASH may reasonably require in order to give effect to the provisions hereof and for the better granting, transferring, assigning, charging, setting over, assuring, confirming or perfecting the security interests hereby created and the priority accorded to them by law or under this agreement.
18. Any amendment of this agreement shall not be binding unless in writing and signed by WASH and the Purchaser.



SPEED QUEEN® MULTI-HOUSING LAUNDRY SOLUTIONS

Rear Control Front Load Washer

Quantum® Gold Pro

Prep for Card | Coin Drop Installed

Built for Reliable Performance

Engineered and built like no other, the Speed Queen® front load washer is designed to be everything people thought a washer couldn't be, beginning with its revolutionary suspension and sensing technology. This groundbreaking innovation manages and redistributes out-of-balance loads to deliver uninterrupted cycles, virtually eliminate vibration and operate so quietly neighboring residents won't even know it's running. It also touts an incredible 440 G-Force extraction speed to maximize moisture removal, reduce dry times and minimize utility costs. And as if that's not game-changing enough, this smooth-running, laundry-optimizing machine delivers increased water efficiency. It's everything you never knew it could be.

- Revolutionary balancing technology
- Industry leading 1200 RPM spln speed exerts 440 G-force extraction
- Integrated meter case
- Extra-wide 15.5° door opening and 180° door swing
- Rugged suspension system
- Easy-to-read digital display
- Large capacity meter case standard
- Multi-level vend pricing
- Individual cycle modifier keys
- Durable stainless steel tub standard
- Four-compartment soap dispenser
- Wash Alert™ capability





Quantum® Gold Pro Control

The Quantum® Gold Pro control delivers a truly premium experience to residents. From intuitive soft touch buttons that walk them through cycle options to multiple actuations (coin, card, mobile) for payment flexibility, this control gives residents the wash and dry options they want, and the revenue potential managers desire.

Rear Control Front Load Washer

Quantum® Gold Pro

Specifications		
Control Option	Quantum Gold Pro	
Color	White	
Capacity - lb (kg)	21.5 (9.5)	
Overall Width - in (mm)	26.875 (683)	
Overall Depth - in (mm)	27.73 (704)	
Overall Height - in (mm)	43.875 (1114)	
Cylinder Volume - cu. ft. (liters)	3.42 (96.8)	
Spin Speed G-Force (RPM)	440 (1200)	
Motor Size - HP (kw)	0.9 (0.67)	
Water Consumption Per Cycle - g (liter)**	13.68 (51.8)	
IWF (Water Factor) - gal/ft ³ (liters/liter/cycle)**	4.0 (0.53)	
MEF ₁₂ (Modified Energy Factor) ft ³ /kWh/cycle (Liters/kWh/cycle)**	2.20 (62.3)	
Available Water Temperatures	Hot, Warm, Cold	
Available Cycles	Normal, Perm Press, Delicates, Bulky	
Electrical Requirements (v/Hz/Ph-Amp)	120/60/1 - 15 Amp	
Water Pressure - p.s.i. (bar)	20-120 (1.4/8.3)	
Drain	Pump	
Cylinder Finish	Stainless Steel	
Net Weight - lb (kg)	260 (118)	
Shipping Weight - lb (kg)	270 (122.2)	
Shipping Dimensions Approx. - in (mm)	Width	34 (864)
	Depth	30 (762)
	Height	44.5 (1130)
Agency Approvals	ULUS	

Models	Drain	Actuation
SFNNCRSP116TW01	Pump	Coin Drop Installed 
SFNNYRSP116TW01	Pump	Prep for Card 

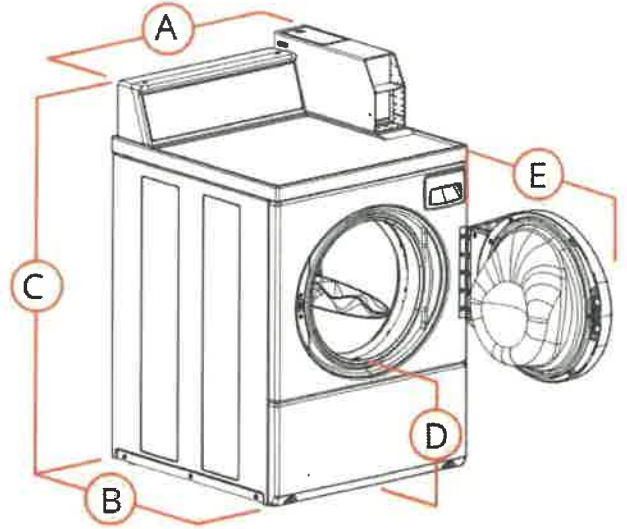

A. Overall Width - in (mm)	26.875 (683)
B. Overall Depth - in (mm)	27.73 (704)
C. Overall Height - in (mm)	43.875 (1114)
D. Floor To Door Opening -in (mm)	14.6 (371)
E. Door Swing - in (mm)	24 (610)

** Average usage based on multiple load sizes and current DOE test protocol. Real usage will vary depending on load size, composition and cycle selectivity.

For the most accurate information, the installation guide should be used for all design and construction purposes. Due to continuous product improvements, design and specifications subject to change without notice. The quality management systems at Alliance Laundry Systems are registered to ISO 9001.

