



Special Meeting

City of Los Angeles Commission on Disability

Thursday, January 15, 2026

2:05 P.M. until the conclusion of business

Edward R. Roybal Board of Public Works Session Room 350,
City Hall, 200 North Spring Street,
Los Angeles, CA 90012

Virtual Meeting Information

Join via Zoom: bit.ly/zoom-lacdod24

Dial by phone: 1 (669) 444-9171

Meeting ID: 896 4264 0290

Real-Time Captioning: bit.ly/streamtext-lacdod

Commissioners

Akiko Tagawa, President

Myrna Cabanban, Vice President

Jorge E. Acevedo, Commissioner

Mary Grace A. Barrios, Commissioner

Robert Bitonte, Commissioner

Iran Hopkins, Commissioner

Alisa Schlesinger, Commissioner

Robert Williams, Commissioner

Louis Herrera, Commissioner

Meeting Information

Commission on Disability regular meetings are held on the 3rd Thursday of each month at 2:00 PM.

Virtual Attendance Information

Public participants may join the Commission meeting via the Zoom link or phone number provided above. Participants joining by phone will be asked for a meeting ID. Please enter 844-7583-0151 followed by the pound sign (#).

Public Comment

Comments by the public on agenda items and on non-agendized matters within the subject matter jurisdiction of the Commission will be heard during the "Public Comment" period of the meeting.

Members of the public who wish to speak on Agendized items and Non-Agendized items shall be allowed to speak for up to two (2) minutes per Agendized item, and two (2) minutes on Non-Agendized items, up to a total of five (5) minutes per meeting. We request that each speaker announce their name before public comment. This is for the benefit of meeting captioners, interpreters, and attendees.

All in-person requests to address the Commission must be submitted to the Commission support staff prior to the Commission's consideration of the item through physical Public Comment cards available at the meeting room entrance.

During virtual meetings all attendees are automatically muted upon entry. Please use the RAISE HAND function to indicate your wish to speak on a specific agenda item. To use the RAISE HAND function, press star (*) and then 9 When called upon, you may UNMUTE by pressing star (*) and then 6.

If you wish to provide documents to the full Commission for consideration on an item, please present the COD Liaison with 20 copies. Otherwise, your material will simply be added to the official record.

Agenda Packet

This agenda packet is available on the Department on Disability Website at <https://disability.lacity.gov/about/commission-disability>. To request to be placed on the agenda packet mailing list, provide your email address to the Commission support staff at the Commission meeting or contact the Department on Disability: 201 North Figueroa Street, Suite 100, Los Angeles, CA 90012; (213) 202-2764; DOD.Contact@lacity.org.

Accommodations

Communication Access Real-time Translation (CART) and American Sign Language (ASL) interpretation are provided at each meeting. Upon request, materials in alternative formats and other reasonable accommodations are available for City-sponsored meetings and events. For additional information or to request an accommodation, please contact the Commission on Disability at least five business days in advance by calling 213-202-2764 (Voice), dial 711 for CA Relay, or email DOD.Contact@lacity.org.

Meeting Agenda

Item One (1) - Request for Remote Participation Option Pursuant to Government Code Section 54953(f)(2)(A)

Item is for **Action**.

Item Two (2) - Public Comment

Item is for **Information**.

Item Three (3) - Approval of the November 20th, 2025, Regular Meeting Minutes

Item is for **Discussion** and **Action**.

Item Four (4) - Presentation from Throne Labs about the services they provide and their recommendations for providing services during the Paralympic and Olympic Games

Item is for **Information**.

Item Five (5) - Presentation from the Department of Cultural Affairs, (DCA) about the City's policies to install murals

Item is for **Information**.

Item Six (6) - Establishment of the Betty Wilson Humanitarian Award

Item is for **Discussion** and **Action**.

**Item Seven (7) - Discuss and Select the Commission on Disability's
Fiscal Year 25-26 Public Hearing Topic**

Item is for **Discussion** and **Action**.

**Item Eight (8) - Commission on Disability FY 2025-26 Work Plan
Updates**

Item is for **Discussion** and **Action**.

Item Nine (9) - Department on Disability Executive Director's Report

Item is for **Information**.

Item Ten (10) - Announcements

Item is for **Information**.

Item Eleven (11) - Adjournment

Item is for **Action**.



Regular Meeting Minutes

City of Los Angeles Commission on Disability

Thursday, November 20, 2025

2:00 P.M.

Edward R. Roybal Board of Public Works Session

Room 350

Los Angeles City Hall

200 North Spring Street

Los Angeles, CA 90012

Zoom Video Conference

Commissioners Present

Akiko Tagawa, President

Myrna Cabanban, Vice President

Iran Hopkins, Commissioner

Alisa Schlesinger, Commissioner

Robert Bitonte, Commissioner

Robert Williams, Commissioner

Louis Herrera, Commissioner

Commissioners Absent

Mary Grace A. Barrios, Commissioner

Jorge E. Acevedo, Commissioner

City Staff Present

Stephen David Simon, Executive Director, Department on Disability
Alison Everett, Assistant Executive Director, Department on Disability
Heather Aubry, Assistant City Attorney, City Attorney's Office
Kayvon Wroten, Department on Disability
Salina Goytia, Department on Disability

Item One (1) - Request for Remote Participation Option Pursuant to Government Code Section 54953(e)(2)(a)

Action Taken: There were no Commission members attending the Commission on Disability meeting remotely. No action required by the Commission on Disability.

Item Two (2) - Multiple Agenda Item Public Comment

Public comment was provided on the following topics applicable to the Commission's scope of work:

- Concerns about the homelessness crisis and alleged violations committed by the Church of Scientology against the disabled and elderly. Noted lack of sufficient response by the City regarding Scientology actions in the public right of way.
- Suggested mandatory training for City personnel regarding intervention and prevention of elder abuse perpetrated by "high-control groups."
- Concerns regarding access and cost barriers to virtual public comment (CPRA/SB 707 Compliance).
- Obstacles to effective code enforcement due to removal of public information
- Requirement for comprehensive synopsis of public comments within the official minutes.
- Addressing the needs of unhoused individuals with Disabilities as a priority.

No action taken, information purposes only.

Item Three (3) - Approval of the October 16th, 2025, Regular Minutes

The Commission reviewed the October 2025 Regular Meeting minutes.

Action Taken: President Tagawa moved, and Commissioner Bitonte seconded the motion to approve the minutes of the October 2025 Regular Meeting. The motion passed.

Item Four (4) - Presentation by Nathaniel Vergow, Deputy Chief Program Officer, from the Los Angeles Homeless Services Authority (LAHSA) about people with disabilities experiencing homelessness in Los Angeles.

Nathaniel Vergow discussed how the the Los Angeles Homeless Services Authority (LAHSA) is working to address homelessness, facing an "Outreach Imbalance" where expanded outreach exceeds the availability of interim and permanent housing. The standard System Pathway for unhoused individuals moves from Outreach to Interim Housing/Shelter, then Housing Navigation, and finally to Permanent Housing (including Permanent Supportive Housing). Data shows the unhoused population has a high rate of disability, with about 25% experiencing serious mental illness and 14% having a physical disability. LAHSA's accessibility efforts include tracking features in the HMIS, addressing restrictive housing unit requirements , creating a Universal Housing Application, and simplifying In-Home Supportive Services (IHSS) access in shelters.

Questions from the Commissioners followed.

No action taken, information purposes only.

Item Five (5) - Presentation by Victoria Jump, Assistant Director from the Los Angeles County Regional Coordinating Council on Aging and Disability's Community Engagement and Communications Workgroup on their Communications Guide.

Victoria Jump discussed the new Communications Guide, developed by the Regional Coordinating Council for Aging and Disability, which is a short, succinct resource for professionals in the disability and aging fields. Its purpose is to promote accessible and positive communication, reduce ageism and ableism, and offers best practices, definitions, and specific tips for various communication challenges, including those related to different disabilities and language access. Commissioners viewed it as a quick reference tool for providers. A plan is being developed for training and disseminating the guide to all providers and a suggestion was made to partner on a separate reference material aimed at the media. Commissioners were asked to send any feedback on the guide to Kayvon by the end of December for a potential final draft and publication in January.

No action taken, information purposes only.

Item Six (6) - Commission on Disability FY 2025-26 Work Plan Updates

The Ad Hoc Committees provided the following updates:

- Ad Hoc Committee 1 (LA28 Games Support):
 - No updates given.
- Ad Hoc Committee 2 (Disability Cultural Impact):
 - Commissioner Cabanban identified a potential candidate for the first Betty Wilson Humanitarian Award.
- Ad Hoc Committee 3 (Healthcare and Social Security Access):
 - Commissioner Bitonte informed the Commission that he would like to invite LA Care to a future meeting to discuss how many enrollees they are expected to lose due to diminished healthcare subsidies after the first of the year.
- Ad Hoc Committee 4 (Affordable and Accessible Housing):

- The Committee reported that it completed its objective of receiving a presentation from the Los Angeles Homeless Services Authority (LAHSA).

No action taken, for information purposes only.

Item Seven (7) - Department on Disability Executive Director's Report

The Department on Disability (DOD) Executive Director, Stephen David Simon, provided the following information as part of his Executive Director's Report:

- Encouraged Commissioners need to think about a topic for the Commission's March public hearing and to agendaize a discussion on it for the January meeting
- Noted there is no meeting in December.
- Noted that a presentation on the City's accessibility plan for the Games will be given in February.
- Noted the COD FY 24-25 Annual Report was approved and needs a cover letter from the President then will be submitted to the Deputy Mayor.
- Highlighted the Department's Durable Medical Equipment program recently held a successful event, and that the program is expected to exhaust its FY 2025-26 funding by December.
- Noted the Department's budget and stated a comprehensive, \$6.2 million budget (including funds for the Games) was submitted to the CAO's office.
- Noted the Department's Reel Abilities Film Festival hosted a community forum to find a new lead and support for the festival. A smaller event is being planned for the coming year, and they are seeking community partners.

No action taken, for information and discussion only.

Item Eight (8) - Announcements

Announcements from Commissioners and City staff and requested agenda items for future Commission meetings.

- Commissioner Bitonte noted that the recent Mayor's meeting dedicated time to the Games but had little mention of disability access.
- Commissioner Tagawa agreed with Commissioner Bitonte, adding that the Paralympics were not mentioned alongside the Olympics, and the meeting venue itself had accessibility issues. Also shared a positive experience with accessibility

in a Mongolian art museum. Took a moment to formally recognize the passing of disability rights activist and writer Alice Wong on November 14th.

- Commissioner Williams: Asked if the persisting issues in Hollywood (sidewalks, planters) need to be agendized.
- Commissioner Cabanban: Suggested inviting LA28 to speak to the Commission, as accessibility was barely addressed in a recent transportation meeting they attended.

No action taken, information purposes only.

Item Nine (9) - Adjournment

Action Taken: President Tagawa moved to adjourn in remembrance of Alice Wong and Commissioner Cabanban seconded the motion. The motion passed unanimously.

The meeting adjourned at approximately 3:28 P.M.



Fiscal Year 2025-2026 Work Plan

The Commission on Disability provides a forum for the identification and discussion of difficulties encountered by Disabled persons in our society, and makes recommendations to the Mayor and the City Council on measures which the Federal, State, and local governments may undertake to assure that persons with disabilities may participate without hindrance in the life of our community.

Powers and Duties

1. Advise the Mayor, the City Council and the Department on Disability on the needs and challenges of persons with disabilities in the City of Los Angeles.
2. Hold public hearings at least once a year as a regular or special meeting to take testimony from persons with disabilities and others regarding issues impacting the lives of persons with disabilities in the City of Los Angeles, and report the Commission's findings and recommendations to the Mayor and the City Council.
3. Monitor the program mandates of the Department on Disability and make recommendations to the Mayor and the City Council on program and policy initiatives to improve the service of the Department to the Disability community and provide persons with disabilities in the City of Los Angeles a better opportunity and ability to pursue activities of daily living without discrimination.
4. Review and make recommendations to the Mayor and City Council on funding disability access for City programs and services.
5. Maintain active liaisons with Disability community stakeholders interested in the problems facing persons with disabilities.
6. Promote greater awareness of Disability culture, as well as civic and community engagement of persons with disabilities.
7. Investigate and report to the Mayor and the City Council instances of discrimination based on disability, as well as ableism and attitudinal barriers in

areas including housing, transportation, employment, recreation, public information, health and social services, civil and human rights, and legislation.

8. Perform specific studies and surveys on the needs of persons with disabilities when requested by the Mayor and/or the City Council.
9. Submit an annual report to the Mayor and the City Council on the activities of the Commission.

FY 2025-2026 Ad Hoc Committees

[Ad Hoc Committee #1 - LA28 Games Support](#)

[Ad Hoc Committee #2 - Disability Cultural Impact](#)

[Ad Hoc Committee #3 - Healthcare and Social Security Access](#)

[Ad Hoc Committee #4 - Affordable and Accessible Housing](#)

Ad Hoc Committee #1 - LA28 Games Support

Ad Hoc Committee Members

- Commissioner Acevedo (Chair)
- Commissioner Hopkins
- President Tagawa

Objectives and Action Items

1. Monitor the progress of naming a street to "Paralympic," including requesting an update from the Office of Major Events.
2. Provide a representative from the Commission to serve on the City's Major Events Accessibility Advisory Committee and provide updates on the activities of that Committee at each Commission meeting.

Presentations requested related to Ad Hoc Committee #1

- Presentation by the Office of Major Events about the Games Mobility Plan.
- Presentation by Throne Labs about the process to participate as a games vendor.

Work Plan Updates

September

- President Tagawa appointed herself, Commissioner Hopkins, and Commissioner Acevedo to the LA28 Games Support ad hoc committee.
- The ad hoc committee finalized its objectives and action items.

October

- No updates provided.

November

- No updates provided.

December

- Meeting Canceled.

Ad Hoc Committee #2 - Disability Cultural Impact

Ad Hoc Committee Members

- Vice President Cabanban (Chair)
- Commissioner Hopkins
- Commissioner Williams
- President Tagawa

Objectives and Action Items

1. Establish the "Betty Wilson Humanitarian Award of Excellence"
 - To be awarded by the Commission on Disability to recognize work advancing the interests of persons with disabilities, including developing award criteria and processes for nomination and selection. The award recipient is to be announced annually in October to spotlight Disability Awareness month.
2. Prepare a letter to the Mayor's Office recommending the City adopt Atkinson Hyperlegible Font as the City's primary font.
3. Prepare a letter to the Mayor's Office recommending the City create a mural commemorating LA28 and the Paralympics.

Presentations requested related to Ad Hoc Committee #2

- Presentation from the Department of Cultural Affairs (DCA) about the process to install a mural and what steps are necessary to ensure this process functions effectively.

Work Plan Updates

September

- President Tagawa appointed herself, Commissioners Hopkins, Cabanban, and Commissioner Williams to the Disability Cultural Impact ad hoc committee.
- The ad hoc committee finalized its objectives and action items.

October

- No updates provided.

November

- Commissioner Cabanban identified a potential candidate for the first Betty Wilson Humanitarian Award.

December

- Meeting Canceled.

Ad Hoc Committee #3 - Healthcare and Social Security Access

Ad Hoc Committee Members

- Commissioner Bitonte (Chair)
- Commissioner Schlesinger
- Commissioner Williams

Objectives and Action Items

1. Review and recommend the Commission readopt the previous [policy memorandum](#) issued by the Commission regarding the provision of a mobile Social Security Disability Office.
2. Submit a recommendation to the Mayor that the City support the development of a mobile Social Security Disability Office.

Presentations requested related to Ad Hoc Committee #3

- Presentation from a Healthcare provider about the healthcare benefit denial process and the types of disabilities that are most frequently denied.

Work Plan Updates

September

- President Tagawa appointed Commissioners Bitonte, Schlesinger, and Commissioner Williams to the Healthcare and Social Security Access ad hoc committee.
- The ad hoc committee finalized its objectives and action items.

October

- No updates provided.

November

- Commissioner Bitonte informed the Commission that he would like to invite LA Care to a future meeting to discuss how many enrollees they are expected to lose due to diminished healthcare subsidies after the first of the year.

December

- Meeting Canceled.

Ad Hoc Committee #4 - Affordable and Accessible Housing

Ad Hoc Committee Members

- Vice President Cabanban (Chair)
- President Tagawa
- Commissioner Acevedo

Objectives and Action Items

1. Submit a recommendation to the Mayor regarding the allocation of additional funding to support people with disabilities who are experiencing homelessness.
2. Make a recommendation to the Mayor that the City adopt the policy of referring to affordable housing as “affordable accessible housing.”
3. Submit a recommendation to City Council offices regarding possible strategies to support people with disabilities who are experiencing homelessness.

Presentations requested related to Ad Hoc Committee #4

- Presentation from the Los Angeles Housing Department (LAHD) about an update and overview of the Accessible Housing Program (AHP), noting how funding allocations are determined for these programs and what factors influence the process.
- Presentation from the Los Angeles Homeless Services Authority (LAHSA) about people with disabilities experiencing homelessness in Los Angeles.

Work Plan Updates

September

- President Tagawa appointed herself and Commissioners Acevedo and Cabanban to the Affordable and Accessible Housing ad hoc committee.
- The ad hoc committee finalized its objectives and action items.

October

- The Commission received a presentation from the Los Angeles Housing Department (LAHD) about an update and overview of the Accessible Housing Program (AHP).

November

- The Committee reported that it completed its objective of receiving a presentation from the Los Angeles Homeless Services Authority (LAHSA).

December

- Meeting Canceled.

Presentation Schedule

FY 2025-2026

September 2025 - Regular Meeting

- Presentation by **Los Angeles World Airports (LAWA)** on the plan for the LAX Automated People Mover Train System with an emphasis on accessibility for people with disabilities.

October 2025 - Regular Meeting

- Presentation from the **Los Angeles Housing Department (LAHD)** about an update and overview of the Accessible Housing Program (AcHP).

November 2025 - Regular Meeting

- Presentation from the **Los Angeles Homeless Services Authority (LAHSA)** about people with disabilities experiencing homelessness in Los Angeles.
- Presentation from the **Los Angeles County Regional Coordinating Council on Aging and Disability's Community Engagement and Communications Workgroup** on their Communications Guide.

December 2025

- **Meeting Cancelled**

January 2026 - Regular Meeting

- Presentation from **Throne Labs** about the services they provide and their recommendations for providing services during the Paralympic and Olympic Games.
- Presentation from the **Department of Cultural Affairs, (DCA)** about the City's policies to install murals.

February 2026

- Regular Meeting

March 2026

- Public Hearing

April 2026

- Regular Meeting

May 2026

- Regular Meeting

June 2026

- Officer Nominations

July 2026

- Officer Elections



**BETTY WILSON
HUMANITARIAN
AWARD OF EXCELLENCE**



The Betty Wilson Humanitarian Award of Excellence is presented to a person who has increased disability awareness and made significant contributions to accessibility and quality of life for people with disabilities and in the City of Los Angeles Disability communities.

Judging Criteria

The Betty Wilson Humanitarian Award of Excellence honoree will be selected based upon nominations submitted and approved by the City of Los Angeles Commission on Disability. Current commissioners are not eligible for nomination or selection.

Eligibility Criteria

The Betty Wilson Humanitarian Award of Excellence is awarded to an individual who has lived or worked in the City of Los Angeles that has had direct involvement in improving accessibility and quality of life for people with disabilities, or to an organization or agency based in the City of Los Angeles that has fostered community transformation as it relates to people with disabilities.

Awards Presentation

The Betty Wilson Humanitarian Award of Excellence will be presented and the awardee will be recognized at the Commission on Disability meeting in June of each year.

Timeline

January

- The Commission on Disability President creates the Betty Wilson Humanitarian Award of Excellence ad hoc committee.

February

- The ad hoc committee recommends updates to the nomination and selection process, if needed.
- The Commission on Disability announces the award nomination period during its February meeting.

March 1 - 30

- Nomination period. The Commission on Disability submits nominations to Commission liaison.

April - May

- The ad hoc committee will determine eligibility and recommend awardees for Commission approval. The Commission on Disability President dissolves the ad hoc committee after submission of the recommendation.
- The Commission on Disability approves the awardee.

June

- Awardee is awarded and recognized at the June Commission on Disability meeting. At BPW Hearing Room.

Nomination Form

(To be provided as a Google Form)

The Betty Wilson Humanitarian Award of Excellence is presented to a person who has increased disability awareness and made significant contributions to accessibility and quality of life for people with disabilities and in the City of Los Angeles Disability communities.

Nominee's Contact Information

Name:

Address:

Phone:

Email:

Has the Nominee lived or worked in the City of Los Angeles? Yes / No

Nomination Submitted By

Commissioner Name:

Tell Us About The Nominee

Please detail your nominee's significant contributions to enhancing accessibility and quality of life for individuals with disabilities within the City of Los Angeles. Additionally, explain how your nominee exemplifies the core values, vision, and dedication necessary to support inclusion for the broader Disability Communities.

Suggested Public Hearing Topics

- Rideshare accessibility (including rideshare, taxi, air taxi, and similar)
- Emergency Evacuation
- Affordable and accessible housing



City of Los Angeles Commission on
Disability Presentation

January 15, 2026



Throne is on a mission
to meaningfully
expand access to
clean and delightful
bathrooms



Features

Thoughtful and inclusive design

- Running Water Sink
- Flushing Toilet
- Climate Control
- Robust Ventilation
- All cleaning & supplies
- All maintenance & repairs
- All consumables
- ADA Accessible
- 24/7 Remote monitoring
- User Support
- Data Usage Reports
- Baby Changing Station
- Graffiti resistant wrap
- Pro-Accountability Access

Baby Changing Station ▶



Menstrual Pad Dispenser ▶



FAST COMPANY



World
Changing
Ideas
2025

TIME
BEST
INVENTIONS
2025

4.3/5

average cleanliness rating



91%

say Throne is "Good" or "Great"



>90%

Uptime



Throne Growth

- Served over 1,000,000 uses nationwide
- 40 Thrones publicly across LA County +
- Working with LA Metro, Long Beach, Beverly Hills and Fullerton
- 35 Thrones at LA Metro stations and

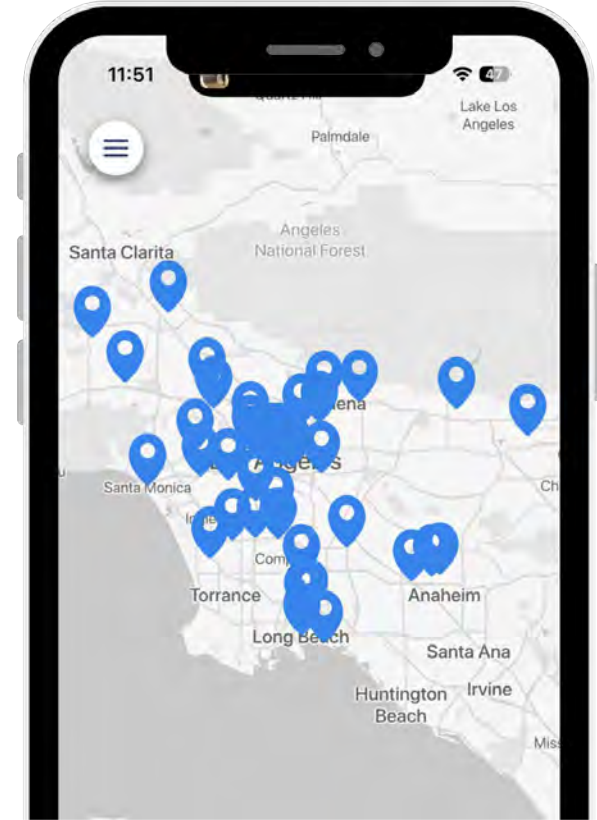

Throne Specifications & ADA Certification

Throne Size 8'3"H x 8'W x 7'1"D
9'7"H x 8'W x 7'1"D *with optional solar panel*

ADA Compliant Exceeds ICC A117.1 ADA requirements and all units certified by a third party inspector.

Ramp included with every Throne and configurable left, right and straight ahead.

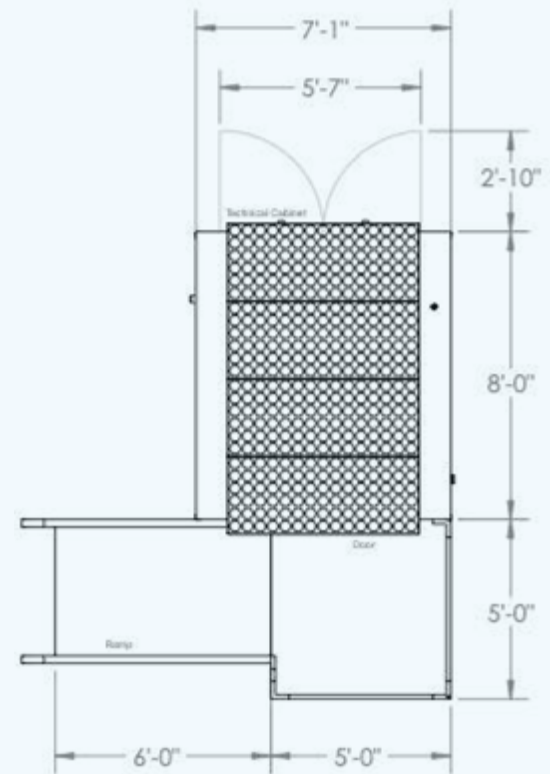

Throne in Action

Accommodations for Blind & Low Vision



NaviLens

Throne has partnered with NaviLens to enable discovery, entry and interior wayfinding with NaviLens and the NaviLens Bathroom Kit.



“Throne + NaviLens is marrying accessibility tech to a mainstream solution. The difficulty when you're visually impaired and traveling is trying to find a bathroom and the accessibility of that bathroom. We all know that a public restroom is a petri dish. The fact that there's a mostly hands-free way of navigating it is really neat for me.

- Louis Do, Accessibility Consultant

Anti-loitering System

MacArthur Park homeless encampment is across the street putting Throne's anti-loitering system to the test.

5.6%

Users reached 10-
minutes

0.7%

Users had repeat
offenses and lost
access

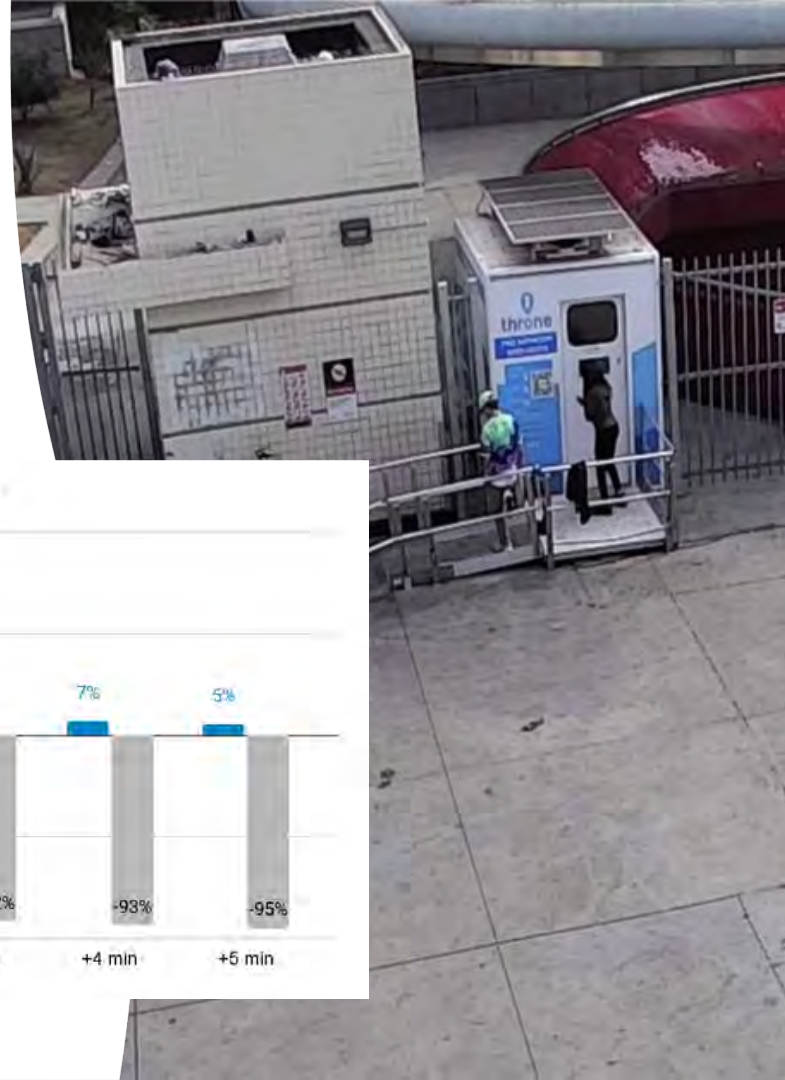
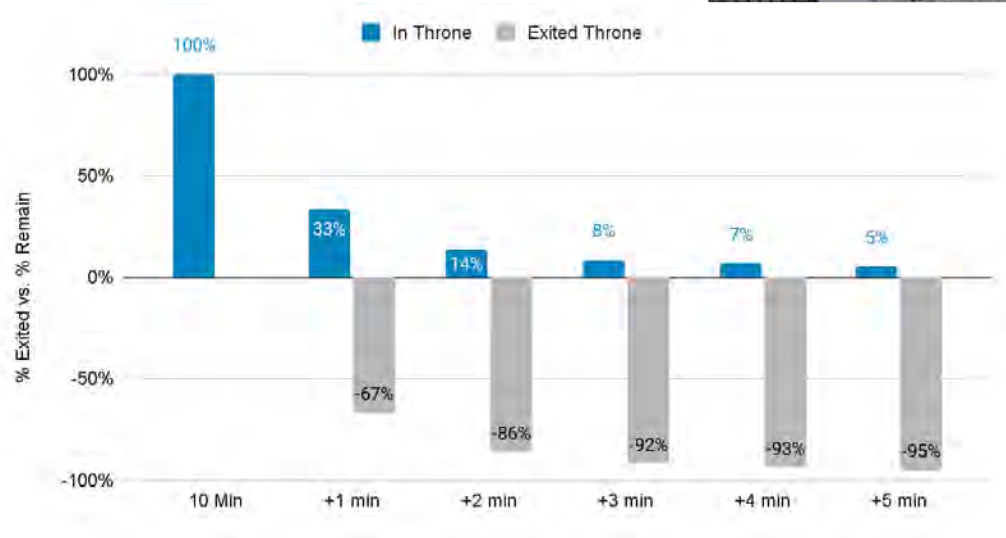

10-minute Accommodations

We are working on a system to tag users to receive extra time, facilitated by partners that interface with individuals with mobility issues or other relevant needs.

We'd love your ideas on who we should be working with!

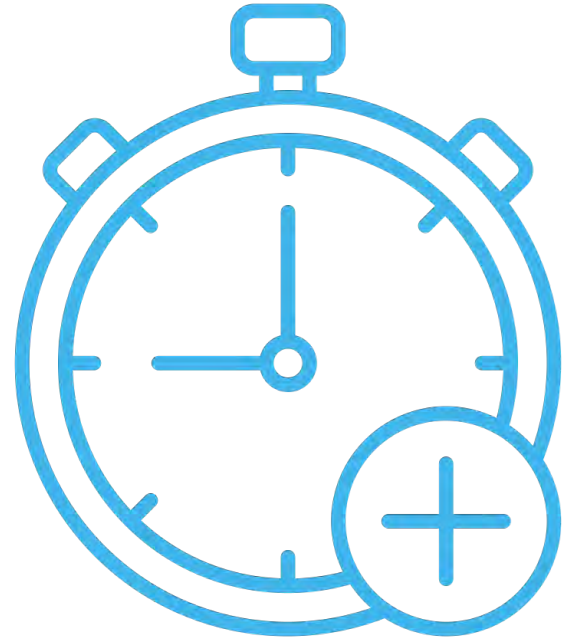

Questions & Discussion





Department of Cultural Affairs (DCA)

CITYWIDE MURAL PROGRAM

Services, Resources and Stewardship for the City of Los Angeles

Yami Duarte, Arts Manager, Mural Program (DCA)

Jessica Ramirez, Arts Associate, Mural Program (DCA)

Presentation to the City of Los Angeles, Department on Disability, Commission





INTRODUCTION

Challenges of operating a City Mural Program

- **LA City population** - 3.9 million residents
- **Rich history of murals** - Originally called the Mural Capital of the World; 1930s to now (DCA database of 2000+ murals)
- **Advertisement vs. Mural** - Mural ban: 2002 to 2013 moratorium
- **Representation** -Diverse communities and need for representation: East LA, San Fernando Valley, Venice Beach, Hollywood, South LA, Metro Downtown etc.
- **Vandalism and the elements**



INTRODUCTION

Rewards of operating a City Mural Program

- Various voices and ideas are in the visual landscape of the City
- Continue the tradition of storytelling and education through murals
- Murals can beautify, spark curiosity and inspire
- Community pride and engagement in the mural design process
- Encourage the creation of “Original Art Murals” as defined by the City Mural Ordinance
- Protect registered Original Art Murals
- Signage is permitted separately from Original Art Murals





SERVICE/ MURAL HOTLINE

As a publicly facing program of a City Department

- Inquiries about murals: registered, contact for artist, title, year etc.
- Reports of damaged or vandalized murals; lots of repair
- Property owners - clean, repair, funding to restore
- All types of organizations, architects, developers, businesses, hotels, sign companies
- Academic research
- Artists: opportunities, looking for walls, “How do I do a mural?”





SERVICE/ LIAISON

The Mural Program coordinates with:

- Artists, property owners, conservators, City Attorney, etc.
- Department of Building Safety- Customer Service Reports, referrals for permits
- City Planning: Zoning compliance, Historic preservation review (Office of Historic Resources)
- Public Works: funding for anti-graffiti coating, cleaning, and assessing damages
- Cultural Affairs Commission- applications, review and approve/deny murals on City Property
- Council Districts, Mayor's Office
- General public, organizations
- Dept. of Rec and Parks and other Departments with murals (200+)
- State property such as CalTrans and LAUSD
- LA County and Metro





RESOURCE/ ADMINISTRATIVE

- Manage conflict between stakeholders, artists and officials
- Have knowledge of current issues around new murals and existing murals
- Release opportunities such as Request for Qualifications (RFQ), Proposals (RFP) and Ideas (RFI)
- Contract drafting with City Attorney to pay muralists, curators, historians, designers
- Supervise and coordinate projects
- Ensure accountability with legal agreements i.e. covenants
- Connect free services such as the application of protective coatings and cleaning of murals
- Advise on additional permits i.e. Historic Cultural Monuments and special materials
- Administer the Mural Ordinance





STEWARDSHIP/ TAKING CARE

- Artist Selection Panels
- Collaborate on themes for the murals
- Program Youth Apprenticeships
- Artist Workshops (best practices in proposal development)
- Facilitate community meetings
- Site visits (safety and logistics)
- Artists Rights (VARA/CAPA)
- Ensure murals are coated





STEWARDSHIP/ ARCHIVES

- The database includes many types of properties: City property, private property, historic buildings
- The basics - size, budget, location, funding source, restoration history
- Reporting to Council Offices and Mayor on the status of murals
- Legal documents and Maintenance Manuals
- Maintenance responsibility
- Contact information for artists, organizations etc.
- Budget reporting, analysis, and allocation
- Track an artist's history
- Some murals no longer exist which is a historical record



STEWARDSHIP/ RESTORATION

Sometimes in consultation with a conservator



Original Artist works on site

by repainting the mural based on archival photographs and existing imagery.

*Gintong Kasaysayan, Gintong Pamana (Filipino Americans:
A Glorious History, A Golden Legacy*
Eliseo A. Silva
Restoration in progress; Date of creation 1995
Located on private property in District 13



Original Artist works in studio

to replicate the imagery on a substrate and installs the mural.

Moratorium: Black and White Mural
Gronk and Willie Herron III
Date restored 2015 by Willy Herron III and Leah Moscoso
Date created 1979
Located in Estrada Courts Housing Projects in District 14

STEWARDSHIP/ CONSERVATION

Certified conservator



Conservators and Original Artist

Artist inpaints losses alongside a certified Conservator who assesses the condition, prepares the surface, coats the mural and prepares initial and final reports in coordination with the artist.

Central Avenue Jazz
AysIm
Date conserved 2023 by Zebala and Partners
Date created 2011
Located on Council Office property in District 9



Conservators only

Artist opts out of the inpainting process or the artist is deceased and heirs grant permission to DCA.

Blue Moon Trilogy
Russell Carlton
Date conserved 2022 by FACL Inc.
Date created 1987
Located on Caltrans property in District 2





MURAL ORDINANCE REGISTRATION

What is an Original Art Mural (OAM)?

Original Art Mural Definition: A one-of-a-kind, hand-painted, hand-tiled, or digitally printed image on the exterior wall of a building that does not contain any commercial message.

For definition purposes, a commercial message is any message that advertises a business conducted, services rendered, or goods produced or sold.

What is a Vintage Mural (VAM)?

A mural that existed on a private property prior to the adoption of the mural ordinance (October 2013).

Why register a mural with the City?

- *Legal record*
- *Protects the mural from complaints*
- *Free protective coating and cleaning*
- *Mural remains for a minimum of two years*
- *Invoke VARA/CAPA rights*
- *Almost 200 registered OAM and 300 VAM*
- *Future preservation*

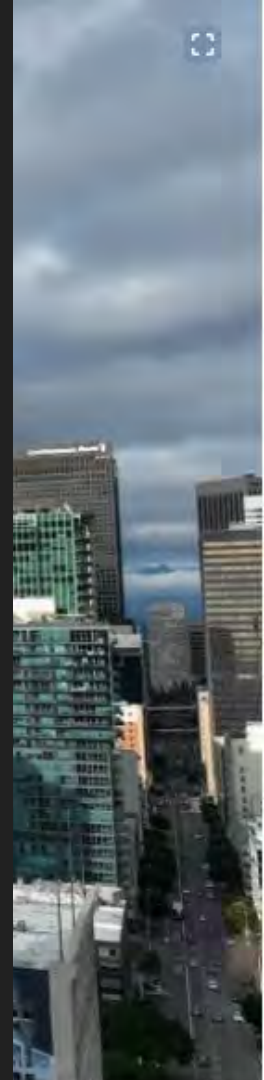

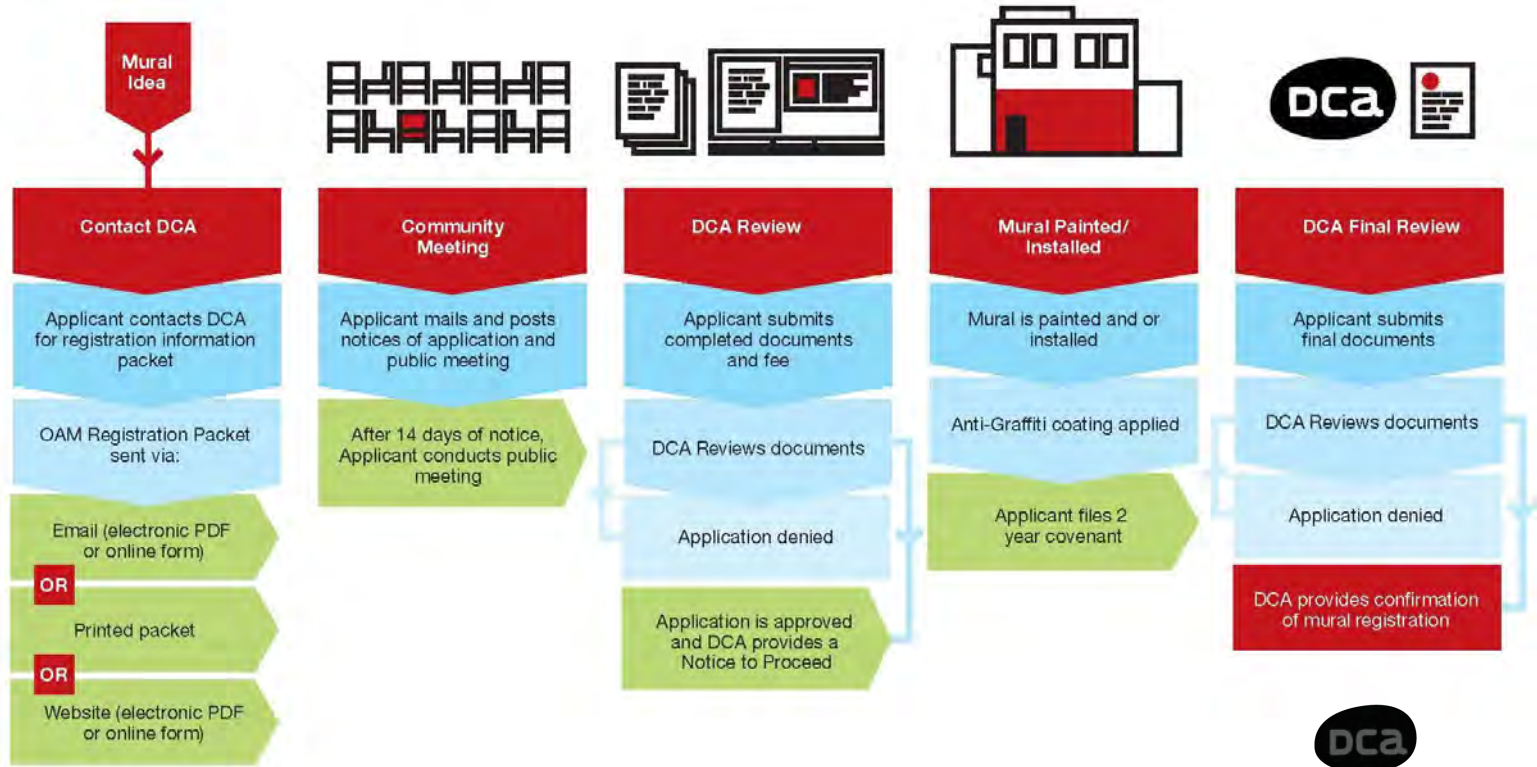

NEW PROGRAMMING MURAL WORKS

New Youth and Creative Workers Mural Program



CALL FOR MURAL WORKS
for Mural Restoration and Conservation

Open to professional artists and artists living in the County of Los Angeles

Request For Proposals (RFP)

City of Los Angeles
Department of Cultural Affairs (DCA)
Public Art Division

Request for Proposals (RFP)

Mural Restoration and Conservation Projects

The Department of Cultural Affairs (DCA) is seeking muralists to program their own historically significant murals located in the City of Los Angeles that need conservation. The mural conservation proposal must include a paid youth apprenticeship opportunity for young people from the mural's local neighborhood. Selected mural conservation projects should also depict the social justice history of the mural, notable cultural figures, or important histories that are meaningful to residents.



professional growth to muralists who are interested in hiring and training the next generation of muralists in our city. It will also provide paid jobs for young people in three neighborhoods while providing a public model for looking in the same future.

To align with the goal of increasing equity, DCA will prioritize the mural restoration projects in neighborhoods that have been most affected by the COVID-19 pandemic. Specifically, neighborhoods with high poverty rates, higher population densities, and neighborhoods with higher populations of people of color who have borne the largest brunt of the pandemic. The funding allocation model will weight submissions based on the applicant's alignment with the program goals and proposed locations.

Goals

The Program will be to provide training directly to muralists to work with and train young people in the process of mural conservation projects.

The main goals of Mural Works are to:

- Provide more opportunities in local institutions that have been historically impacted by the pandemic.
- Invest in paid youth apprenticeships and mentorships.
- Improve the visual landscape in lower socioeconomic neighborhoods.

Background and Context

Mural Works is a pilot program developed by the Department of Cultural Affairs (DCA) in response to Mayor Garcetti's 2020 adopted Social Justice Budget to help offset the ongoing economic impacts of the COVID-19 pandemic incurred by muralists and young people in lower socio-economic communities.

Mural Works will allocate funding to muralists and young people living and/or working in neighborhoods that have historically gone unacknowledged during the pandemic. It will provide opportunities for personal and



Preservation of these historic murals will serve as a vital reminder, connect them to the social justice themes of today, and inspire multiple conversations between the past and the present.



Call for Mural Ideas

Mural Works Request for Ideas (RFI)

The Department of Cultural Affairs (DCA) is initiating a Request for Ideas process (RFI) for individual muralists or teams to submit their ideas for new, socially engaging, mural projects, while supporting the advancement of young apprentices in the trade. DCA is seeking mural concepts that are centered around social justice, notable cultural figures, or important histories relating to a specific neighborhood.



To view or download this RFI online, please visit: culturela.org/calls

9.06.23

Submission Deadline

Open to professional artists and artist teams living in the County of Los Angeles

Mural Works Request for Ideas — Page 2 of 5

Mural Works is a pilot program developed by the DCA in response to Mayor Garcetti's adopted Social Justice Budget to help offset the ongoing economic impacts of the COVID-19 pandemic incurred by muralists and young people in lower socioeconomic communities.



MURAL WORKS GOALS



Artist Orlando Castillo titled "Contributions of Asians"

- Create new murals to serve as cultural markers, connect them to the social justice themes of today, and inspire multiple conversations between the past and the present.
- Provide opportunities to local muralists who have been financially impacted by the pandemic.
- Invest in paid youth apprenticeships and mentorships.
- Improve the visual landscape in lower socioeconomic neighborhoods.
- Increase viewership online that will reimagine public art in the city.

MURAL WORKS SOCIAL JUSTICE THEME



Artist Rudy Martinez titled "Do You Fear For Your Child"

*What does social justice mean in the context of your art?
What are the social justice themes of your mural idea and why are they important?*

How does the mural relate to the neighborhood?

- Is it about race, environment or the economy?
- Does the location reflect low socioeconomic data?
- Does the mentor's lesson plan explore a social justice theme?
- Is there actual social justice imagery? Is the imagery figurative, typographic, narrative or portraiture?
- Is it through the public engagement strategy that social justice is addressed?
- Is it through the artist's technique?
- Is it a memorial?
- Does it mark a significant event that occurred at the location?



Artist Corie Mattie (left)
"Hollywood Unsung Heroes"
Highland Avenue Hollywood, CA
Copyright 2024



Artist Michael Rangel
"Streets of Angels"
Avalon Blvd. South Los Angeles, CA
Copyright 2024



©
Artist Madeline Mackenzie
"The Mind Grows a Flower"
Avenue 50 Highland Park, CA
Copyright 2024



©
Artists Maryrose Mendoza and Christine Morla
"Mga Magiting na Babae, Valient Filipina Women"
Historic Filipino Town, CA
Copyright 2024

Thank you!

Yami Duarte Yami.Duarte@lacity.org Jessica Ramirez Jessica.Ramirez@lacity.org

